

# Euclid 60

LED linear lighting system IP 65

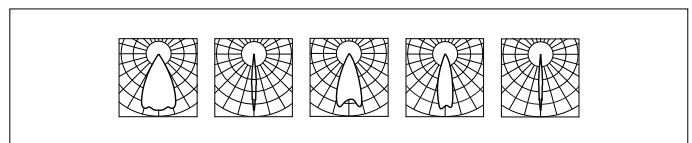
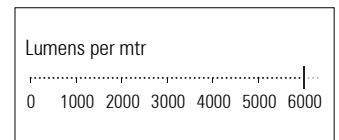
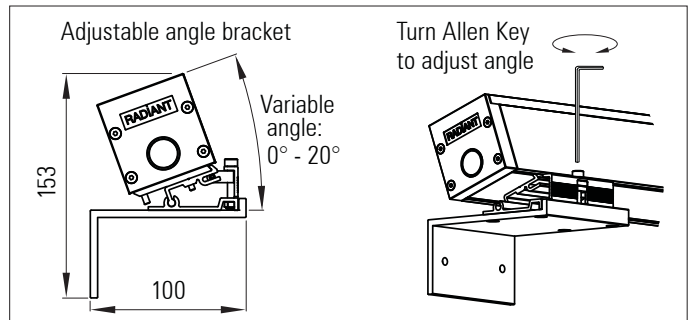
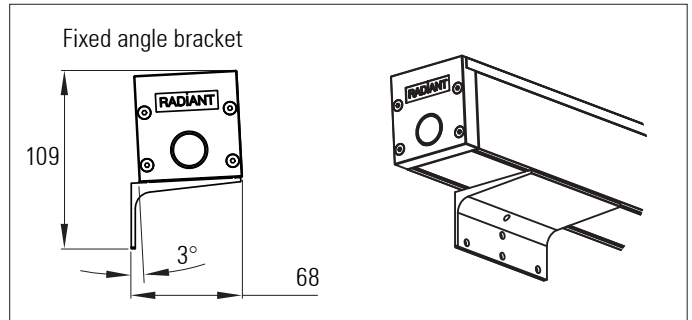
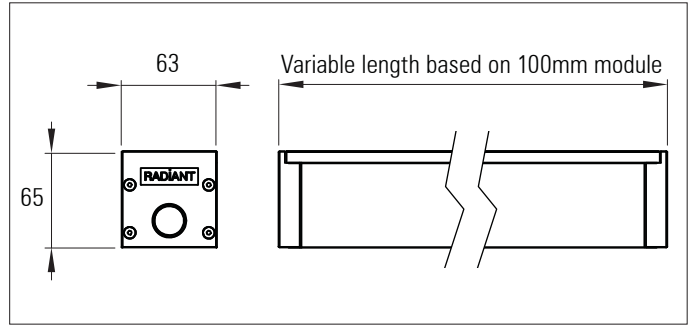

## Euclid 60 IP65 with lenses

High power, IP 65 rated LED linear lighting system

### Product description:

Exterior wall grazing and wall washing applications

Integral mains voltage AC to DC constant current drivers

A wide variety of lens and reflector options can be fitted to the system

A wide range of LED colour temperatures and CRI options are available

Satin black, satin white or any RAL paint colour finish

Custom lengths based on a 100 mm module up to 2 mtrs

Various mounting options and bracket types are available

16 Amp IP67 connectors join strips together on-site

Various dimming options available: 1 - 10, DALI, DMX

Micro louvre available for glare control

Side, back and end power feed options allow continuous lighting without dark areas - LED pitch is maintained between the individual luminaires

Product Code	IP	No. of LEDs per mtr.	Length (mm)	Colour Temp. (K)	CRI	Optics	Bracket Type	Cover	Feed	Finish
EUCLID 60	65	40=25mm 20=50mm LED spacing	100mm -increments of 100mm up to- 2,000mm	27=2,700k 30=3,000k 35=3,500k 40=4,000k 45=4,500k 50=5,000k RGB RGBW RGBA	80 90	ww 120° W 84° M 41° N 16° E 18x48°	Adjustable Fixed	Clear Frosted	End Back	Black White Any RAL- colour