

DATA SHEET

XID: Xicato Intelligent Drivers

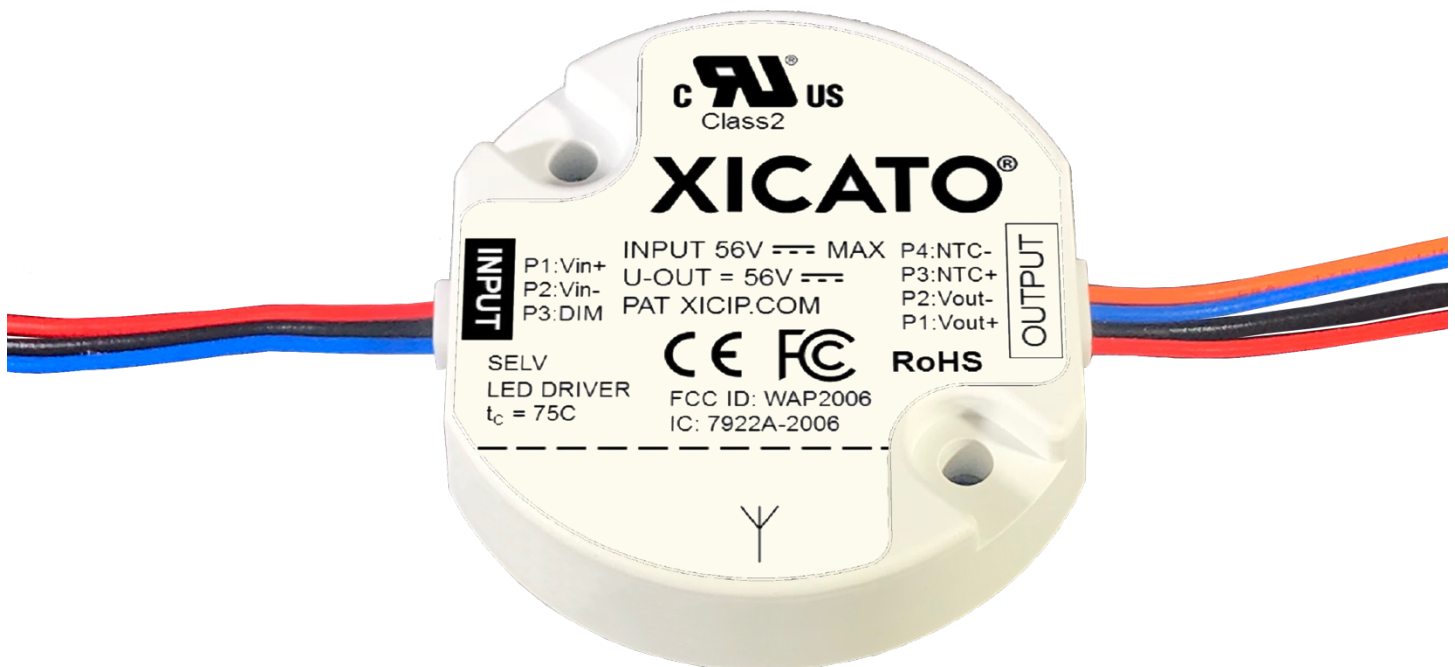

Figure 1: Xicato Intelligent Driver (XID) is just $\varnothing 46\text{mm} \times 12\text{mm}$.

About Xicato

Xicato designs and develops light sources and electronics that enable architects, designers and building managers to create beautiful, smart spaces in which people love to live and work. With thousands of installations around the globe, Xicato continues to be a leading supplier of high quality lighting solutions. Xicato is defining the future of intelligent light sources by integrating electronics, software and connectivity. Founded in 2007, Xicato's headquarters is based in Silicon Valley and the company has offices in China, Japan, Europe and the US.

For further information, visit www.xicato.com.

ABOUT THIS DOCUMENT

This is just one of many documents and tools available from Xicato to assist lighting designers, specifiers, and luminaire manufacturers in understanding and using Xicato products. These include:

- Datasheets
- Test reports, including third party LM-80, UL, CE, and FCC
- Accessory selection tools for heatsinks, optics, and drivers
- CAD files and drawings
- IES files
- Application and Technical Notes
- Training presentations
- Sales brochures
- Technical whitepapers
- ... and much more

Go to the Xicato website under Support / Documents and Tools, or contact your local Xicato representative for more information

TABLE OF CONTENTS

XID: Xicato Intelligent Drivers	1
About This Document	2
Table of Contents.....	2
Table of Figures	2
General Description	3
Features.....	3
Ordering Guide.....	4
Mechanical, Electrical and Wireless Specifications	5
Wireless Specifications.....	8
Firmware Specifications	9
Internal Sensor Data Collection & Storage	10
Mechanical Drawings	11
XID Performance vs. Intensity and Vf.....	14
Warranty.....	16
Regulatory & Agency Approvals	16

TABLE OF FIGURES

Figure 1: Xicato Intelligent Driver (XID) is just ø46mm x 12mm.....	1
Figure 2: XID wiring diagram	13

GENERAL DESCRIPTION

XID – XICATO INTELLIGENT DRIVER

Xicato Intelligent Drivers (XID) are compact, DC-powered, wireless Bluetooth-controllable LED drivers that can provide constant current control to a wide variety of LED luminaires. XID can be mounted inside a luminaire or inside a track adapter, for example. Multiple XID can be mounted on 24V or 48V DC track powered by a single high capacity power supply unit (PSU), or can be individually powered by a separate, lower-powered AC-DC PSUs. Both XID models provide extremely accurate, programmable constant current output with deep, IEEE 1789-compliant dimming to 0.1% with Bluetooth wireless and 0-10V control.

FEATURES

PROGRAMMABLE DC INPUT VOLTAGE

XID can be programmed by the luminaire manufacturer or distributor using the Xicato Configuration Tool to accept 24V or 48V DC input, for group or individual power from inexpensive, readily-available power supply units.

PROGRAMMABLE, CONSTANT CURRENT OUTPUT

XID maximum current output can be factory limited using the Xicato Configuration Tool (XCT-0101) to between 50% and 100% of rated maximum. For example, XID01-50C1D6P14-A6 has a maximum output of 1400mA, but can be factory programmed as low as 700mA to accommodate lower rated LEDs, smaller fixtures with lower thermal dissipation capacity, or more challenging ambient temperature environments. The factory programmed limit is presented to the end user as 100% from the standpoint of dimming, and the dimming curve is adjusted accordingly to provide deep, smooth dimming to 0.1% with optimal flicker performance.

BROAD OUTPUT VOLTAGE RANGE

XID can control LED arrays with voltages as low as 2.5V, and as high as 45V. This allows XID to control individual LED point sources, COB arrays, linear solutions, and other luminaires up to 63W.

THERMAL FOLDBACK AND SHUTOFF

XID contains internal sensors that detect the temperature of the internal electronics, and which ensure long life by reducing current output in the event that the temperature exceeds the rated temperature of the components. If, after reducing output, the temperature continues to exceed the maximum rating, the XID automatically shuts off to preserve module lifetime, and to allow the user to troubleshoot the installation.

XID provides two output wires that can be connected to an external 47Kohm NTC to track LED (T_c) or overall fixture temperature and provide thermal foldback to protect the LED/fixture from over-temperature situations. LED/fixture foldback temperature can be programmed into the XID by the luminaire manufacturer using the Xicato Configuration Tool (XCT).

BLUETOOTH® CONTROL

XID communicates wireless using Bluetooth Low Energy with sensors, switches, gateways, and mobile devices, providing simple or complex responses to motion and occupancy, ambient light, schedules, and/or user commands.

WIRELESS DATA REPORTING

XID regularly transmits its current intensity setting, temperature, input power (W), input voltage, and total operating hours, allowing proactive maintenance. It also stores a histogram of intensity settings and temperature for the life of the device, which can be downloaded on request from an application for lifecycle analysis and confirmation of warranty compliance. Among other things, this allows Xicato to verify its product warranty of 7-years or 50,000 hours, and allows users to plan replacement intervals well in advance.

BLUETOOTH BEACONS

XID can broadcast Apple iBeacons, Eddystone URI beacons, and/or Alt Beacons, enabling a wide variety of location based information and navigation services.

BLE beacons can act as indoor GPS satellites, allowing mobile apps to provide highly granular, accurate location of users in retail shops, hotels, restaurants, museums, airports, or other public and commercial spaces.

Beacons can also trigger web searches, information screens, or other application responses based on a user's proximity to exhibits, merchandise, or other points of interest.

CONFIGURABLE ADVERTISING POWER AND INTERVAL

Transmission power for XID beacons, operational data, and other data can be programmed independently. Users can set both advertising frequency and power levels, depending on their specific application requirements.

ORDERING GUIDE

XID NUMBERING CONVENTION

Product	Form	Watts	Channels	Input Voltage	Output per channel	Control
XID	01 = ø46mm	25 50	Cx = CC x1 = 1ch	Dx = DC D6 = 24 or 48	Pxx = Programmable x07 = 700mA x14 = 1400mA	A6 = BLE+DIM

ORDER CODES

Part Number ¹	Description
XID01-25C1D6P07-A6	Xicato Intelligent Driver, ø46mm, 25W, DC 24V or 48V, programmable 700mA, BLE+1-10V
XID01-50C1D6P14-A6	Xicato Intelligent Driver, ø46mm, 50W, DC 24V or 48V, programmable 1400mA, BLE+1-10V
XSA-332	Wire harness, 3-pin, TE 2058943-2
XSA-333	Wire harness, 3-pin, TE 2058943-3

Notes:

1. Wire harnesses are not included with the part numbers listed. They are widely available, off the shelf, TE Connectivity products and must be ordered separately. Xicato will carry these as a convenience to our customers.

MECHANICAL, ELECTRICAL AND WIRELESS SPECIFICATIONS

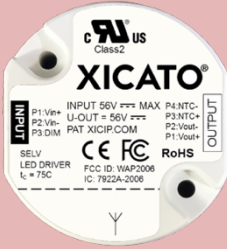
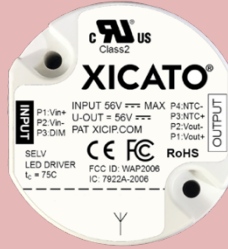
	XID01-50C1D6P14-A6	XID01-25C1D6P07-A6
		
Housing	Injection molded glass filled PBT	
Dimensions (main body)	ø46 mm x 12 mm (1.81" x 0.47"). Recommend aperture ≥ ø47mm to allow space for wires.	
Weight	26 g (0.9 oz)	
Electrical Connections	Input: 3 pins: DC+, DC- (common), 1-10V Output: 4 pins: Constant Current (2 wire). NTC (2 wire).	
Physical Connections (order separately)	Input side: XSA-332, TE 2058943-2 • 3-pin harness with 158.75mm wires Output side: XSA-333, TE 2058943-3 • 4-pin harness with 158.75mm wires	
Input Voltage Settings	24V DC or 48V DC 48V is the default setting. Programmable using Xicato Configuration Tool	
Electrical Protection	Inrush over-current and over-voltage protection. Sustained over-voltage protection via non-replaceable fuse.	
Maximum Output Current	1400mA (default setting)	700mA (default setting)
Minimum Programmable Current	700mA	350mA
Off-State Power Consumption	< 300mW	
Dimming Curve	Logarithmic (default setting) or Linear	
Minimum Constant Dim Level	0.1% of programmed maximum	
Dim to Off	Yes	
Dim to On/Off Intensity Threshold	<0.05%	
On-board Sensors	Temperature, Input voltage, Input voltage ripple	
Ingress Protection	IP20	

RECOMMENDED OPERATING LIMITS

	XID01-50C1D6P14-A6	XID01-25C1D6P07-A6	Notes
Input Voltage range	45.6Vdc to 50.4Vdc		1
Output Voltage range	2.7Vdc to 39Vdc		
Temperature at Tc (max)	-20°C to +75°C		

Notes:

1. Input voltage must be supplied by an SELV (CE) or Class 2 (UR/CNR) power supply to ensure compliant operation with CE or UL safety requirements respectively.

ABSOLUTE LIMITS

	XID01-50C1D6P14-A6	XID01-25C1D6P07-A6	Notes
Minimum Input Voltage (48V operation)	Turn on: 42Vdc Turn off: 41Vdc Shutdown: 30Vdc		1, 2, 3
Minimum Input Voltage (24V operation)	Turn on: 20.5Vdc Turn off: 19.5Vdc Shutdown: 18.5Vdc		1, 2, 3
Maximum Input Voltage	56Vdc		3, 4
Maximum Input Current	1.4A	0.7A	5
Input Power Factor (PF)	1		
Maximum Output Voltage (U-OUT)	56Vdc		2, 6
Maximum Output Voltage (U _{rated})	45Vdc with 48Vdc input / 21Vdc with 24Vdc input		2, 7
Output Voltage (min)	2.5Vdc		
Maximum Rated Output Current (I _{rated})	1400mA	700mA	
Maximum Rated Power (P _{rated})	63W	31.5W	8
Operating Temperature at T _c (max)	75°C		9
Ambient Operating Temperature T _a	55°C		10
Thermal Foldback Temperature	83°C		11
Thermal Restore Temperature	75°C		12
Thermal Shutdown Temperature	88°C		13
Storage Temperature	-40°C to +85°C		

Notes:

- Voltage values listed are those used by the internal voltage measurement circuitry of the XID. Actual voltage applied on device pins may need to be higher.
- Under all conditions, the voltage applied at the input of the XID must be at least 3Vdc above the maximum output load voltage to ensure correct operation of the XID.
- Input voltage must be supplied by an SELV (CE) or Class 2 (UR/CNR) power supply to ensure compliant operation with CE or UL safety requirements, respectively.
- Exceeding the maximum input voltage may cause permanent damage to the XID.
- Maximum input current when driving the maximum rated (U_{rated}) output voltage
- Maximum voltage at output of the XID. U-OUT will never exceed the applied input voltage.
- The maximum voltage that should be driven on the output of the XID to remain within the device specification limits. Exceeding this voltage may cause damage to the device. Under all conditions, the maximum voltage on the output of the XID must be at least 3Vdc below the applied input voltage of the XID to ensure correct operation.
- $P_{rated} = U_{rated} * I_{rated}$
- T_c point is on the bottom side of the housing. Refer to the [Customer Drawing](#) for location details.
- Ambient temperature is provided for reference only and is based on mounting to a Xicato XSA-60 heatsink. Actual acceptable ambient operating temperature may be higher or lower based on not exceeding the T_c point limit of 75°C or the internal operating temperature (Thermal Foldback) limit of 83°C.
- This is the internal temperature of the XID that will cause the XID to reduce the output drive current by 15% from its specified setting.

12. This is the internal temperature of the XID that must be reached after Foldback occurs to restore the output drive current to its specified setting.
13. This is the internal temperature of the XID that will cause the XID to shut down its output. Once the XID has reached a shutdown state, the XID must drop below the Thermal Restore Temperature and be commanded off or power cycled to restore it to normal operation.

WIRING HARNESS WIRING

TE 2058943-2 • 3-PIN HARNESS

Red	V_{in+} ; 48VDC by default; 24VDC as programmed option
Black	V_{in-}
Blue	0-10V dim control; positive voltage referenced to V_{in-}

TE 2058943-3 • 4-PIN HARNESS

Red	LED+
Black	LED-
Blue	NTC+ (optional)
Orange	NTC- (optional)

SUPPORTED EXTERNAL NTC THERMISTORS

The following off the shelf 47Kohm NTC thermistors have been verified to operate with the XID for remote temperature sensing. The default configuration of the XID has external NTC support disabled. NTC must be enabled and configured by the Xicato Configuration Tool.

Manufacturer	Part Number
Murata	NCP15WB473F03RC
Vishay	NTCASCWE3473J
Vishay	NTCLE100E3473JB0

CONNECTION TO XICATO CONFIGURATION TOOL

Requires XCT hardware running XID configuration tool.

Connect XCT to XID power input side. Wired connection is for power only. XCT configuration/programming connection to XID is via Bluetooth.

WIRELESS SPECIFICATIONS

Feature	Specification
Processor	ARM Cortex M0, 32-bit, 48 MHz
Wireless Protocol	Bluetooth Low Energy v4.1
Wireless Spectrum	2.4 GHz ISM band
Bandwidth	1 Mbps
Channels	40
Transmit Power	Configurable to +1.5dBm or +7.5 dBm
Receive Sensitivity	-93 dBm
RSSI Resolution	1 dBm
Signal to Noise Ration (SNR)	> 5:1

FIRMWARE SPECIFICATIONS

CONTROL PROGRAMMING

Feature	Specification
Site Scalability	Over 140 trillion individually addressable nodes (2^{37})
Maximum # of Secure Network Zones	Over 4 billion (2^{32}). Secure networks cannot overlap.
Maximum devices per secure network	32,767 ($2^{15}-1$). One secure network per node.
Max # of Groups per Secure Network	16,535 ($2^{12}-1$). Groups can overlap.
Max # of Scenes per Secure Network	65,535 ($2^{16}-1$). Scenes can overlap. Scenes can span groups.
Max # of Groups per Device	16
Max # of Scenes per Device	32
Protocol Security	AES-128 (128-bit encryption), other mechanisms

DIMMING INFORMATION: BLUETOOTH

Dimming Profile	Logarithmic (default) or linear, configurable
Minimum Dim Setting	0.1% of maximum intensity
Dimming Granularity	0.01% resolution (10,000 steps from 100% to 0.01%)

DIMMING INFORMATION: 1-10V / 0-10V (IEC 60929 ANNEX E)

XID is a 1-10V (0-10V) source.

Dimming Profile	< 0.5V	0% (off) (> 0.75V to turn back on)
	≥ 0.5V and < 1.0V	1% of max current
	≥ 1.0V and < 9.0V	$12.375\% \times (V_{1-10V} - 1) + 1\%$
	≥ 9.0V	100% of max current
Dimming Compatibility	XID is compatible with a wide range of 1-10V sink dimming systems. Refer to dimming compatibility documentation at www.xicato.com .	
Potentiometer Compatibility	100kOhm typical	

DIMMING AND FLICKER

Reference	Luminous Intensity	Modulation Frequency	Risk Level
Reference IEEE Std 1789-2015: "IEEE Recommended Practices for Modulating Current in High-Brightness LEDs for Mitigating Health Risks to Viewers"	100% - 1.25% of max	≥ 3,000 Hz	No Effect
	1.25% - 0.5% of max	≥ 1,250 Hz	Low Risk
	0.5% - 0.1% of max	> 250 Hz	Medium Risk

INTERNAL SENSOR DATA COLLECTION & STORAGE

Real-time reporting	<ul style="list-style-type: none"> Current Intensity level Current Temperature of electronics printed circuit board (PCB). Current Input power, voltage and ripple Current Group membership (provisioned) Current Scene membership (provisioned)
Stored operating history	<ul style="list-style-type: none"> Total operating hours (at > 0% intensity) Power cycles (power on/off) LED cycles (LEDs turned on/off, unit still powered) Histogram of time spent in 9 temp ranges: < 50°C, 50-54°C, 55-59°C, ..., 90-94°C, ≥ 95°C Histogram of time spent in 12 intensity ranges: 0%, 0.1-1.0%, 1-10%, 11-20%, ..., 91-100%
Stored module Information	<ul style="list-style-type: none"> XID part number GTIN Serial number XID hardware revision XID firmware revision Bluetooth firmware revision Maximum current Programmed current
Stored OEM programming	<ul style="list-style-type: none"> OEM serial number (12 bytes) 36 bytes optional free text data

MECHANICAL DRAWINGS

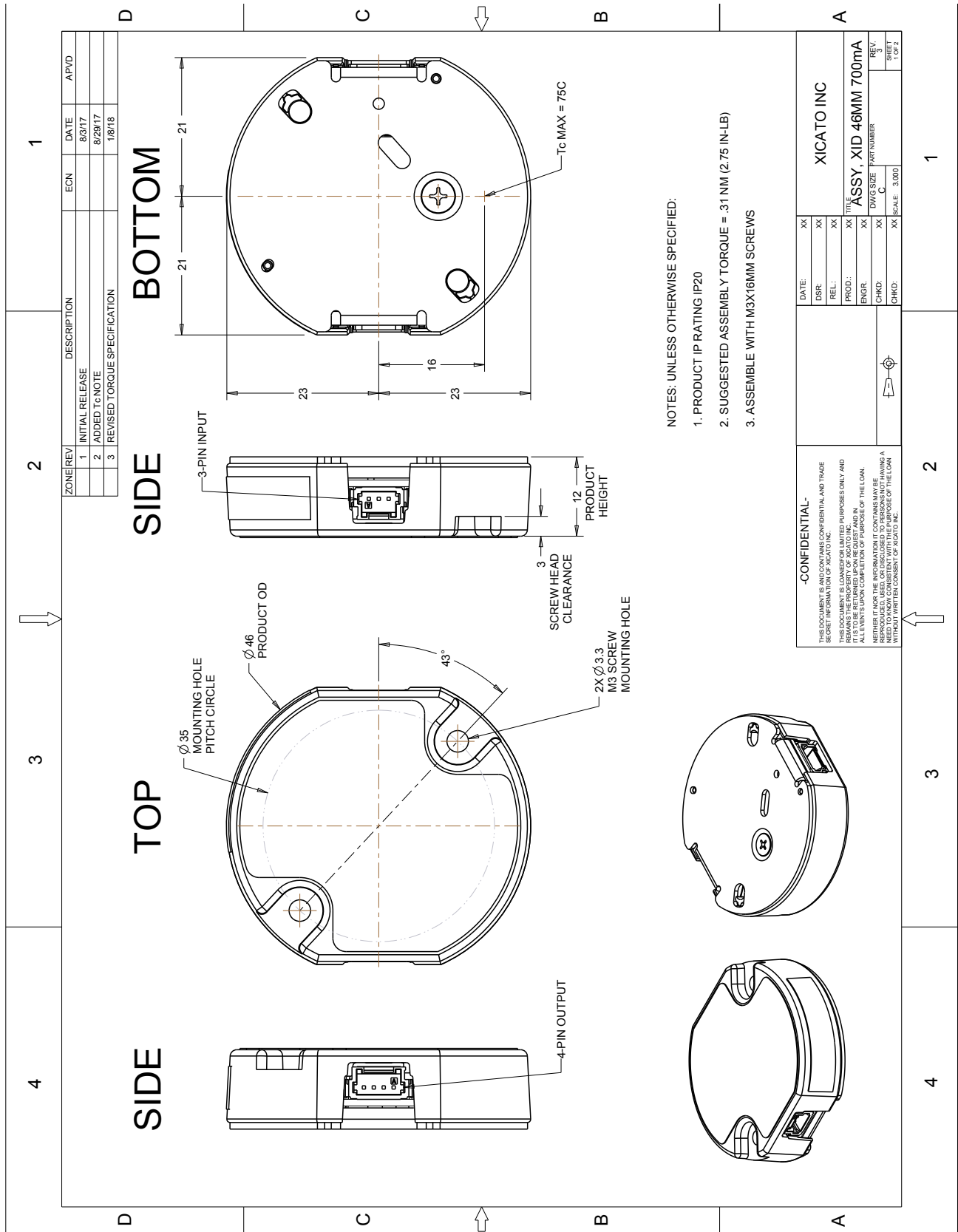

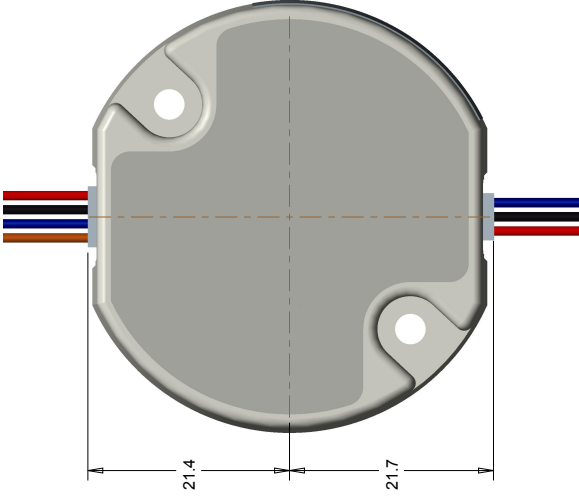
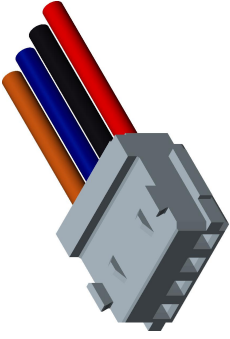
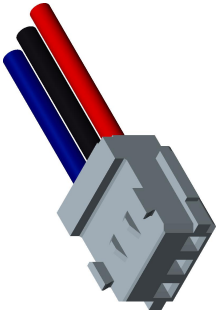
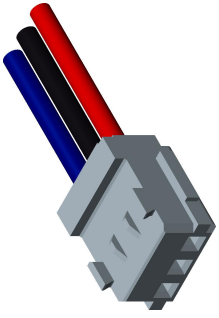
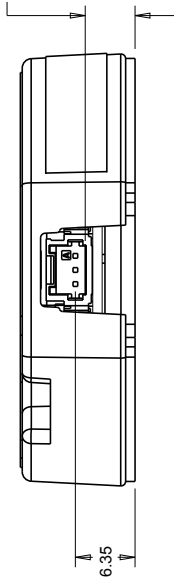
4	3	2	1																																																					
																																																								
																																																								
		<table border="1" style="width: 100%; border-collapse: collapse;"> <thead> <tr> <th colspan="4" style="text-align: left;">XSA-333</th> </tr> <tr> <th>PIN #</th> <th>FUNCTION</th> <th>RATING</th> <th>COLOR</th> </tr> </thead> <tbody> <tr> <td>1</td> <td>LED+</td> <td>24AWG, UL1061</td> <td>RED</td> </tr> <tr> <td>2</td> <td>LED-</td> <td>24AWG, UL1061</td> <td>BLACK</td> </tr> <tr> <td>3</td> <td>NTC+ (OPTIONAL)</td> <td>24AWG, UL1061</td> <td>BLUE</td> </tr> <tr> <td>4</td> <td>NTC- (OPTIONAL)</td> <td>24AWG, UL1061</td> <td>ORANGE</td> </tr> </tbody> </table>		XSA-333				PIN #	FUNCTION	RATING	COLOR	1	LED+	24AWG, UL1061	RED	2	LED-	24AWG, UL1061	BLACK	3	NTC+ (OPTIONAL)	24AWG, UL1061	BLUE	4	NTC- (OPTIONAL)	24AWG, UL1061	ORANGE																													
XSA-333																																																								
PIN #	FUNCTION	RATING	COLOR																																																					
1	LED+	24AWG, UL1061	RED																																																					
2	LED-	24AWG, UL1061	BLACK																																																					
3	NTC+ (OPTIONAL)	24AWG, UL1061	BLUE																																																					
4	NTC- (OPTIONAL)	24AWG, UL1061	ORANGE																																																					
<table border="1" style="width: 100%; border-collapse: collapse;"> <thead> <tr> <th colspan="4" style="text-align: left;">XSA-332</th> </tr> <tr> <th>PIN #</th> <th>FUNCTION</th> <th>RATING</th> <th>COLOR</th> </tr> </thead> <tbody> <tr> <td>1</td> <td>Vin+</td> <td>24AWG, UL1061</td> <td>RED</td> </tr> <tr> <td>2</td> <td>Vin-</td> <td>24AWG, UL1061</td> <td>BLACK</td> </tr> <tr> <td>3</td> <td>0-10V DIM CONTROL, POSITIVE VOLTAGE REFERENCED TO Vin-</td> <td>24AWG, UL1061</td> <td>BLUE</td> </tr> </tbody> </table>		XSA-332				PIN #	FUNCTION	RATING	COLOR	1	Vin+	24AWG, UL1061	RED	2	Vin-	24AWG, UL1061	BLACK	3	0-10V DIM CONTROL, POSITIVE VOLTAGE REFERENCED TO Vin-	24AWG, UL1061	BLUE	<table border="1" style="width: 100%; border-collapse: collapse;"> <tr> <td style="width: 20%;">DATE:</td> <td style="width: 10%;">XX</td> <td style="width: 20%;">XICATO INC</td> </tr> <tr> <td>DSR:</td> <td>XX</td> <td></td> </tr> <tr> <td>REL:</td> <td>XX</td> <td></td> </tr> <tr> <td>PROD:</td> <td>XX</td> <td>TITLE</td> </tr> <tr> <td>ENGR:</td> <td>XX</td> <td>ASSY, XID 46MM 700mA</td> </tr> <tr> <td>CHKD:</td> <td>XX</td> <td>DWG SIZE</td> </tr> <tr> <td></td> <td>XX</td> <td>C</td> </tr> <tr> <td></td> <td>XX</td> <td>PART NUMBER</td> </tr> <tr> <td></td> <td>XX</td> <td>SCALE: 3:000</td> </tr> <tr> <td></td> <td>XX</td> <td>REV: 3</td> </tr> <tr> <td></td> <td>XX</td> <td>SHEET 2 OF 2</td> </tr> </table>		DATE:	XX	XICATO INC	DSR:	XX		REL:	XX		PROD:	XX	TITLE	ENGR:	XX	ASSY, XID 46MM 700mA	CHKD:	XX	DWG SIZE		XX	C		XX	PART NUMBER		XX	SCALE: 3:000		XX	REV: 3		XX	SHEET 2 OF 2
XSA-332																																																								
PIN #	FUNCTION	RATING	COLOR																																																					
1	Vin+	24AWG, UL1061	RED																																																					
2	Vin-	24AWG, UL1061	BLACK																																																					
3	0-10V DIM CONTROL, POSITIVE VOLTAGE REFERENCED TO Vin-	24AWG, UL1061	BLUE																																																					
DATE:	XX	XICATO INC																																																						
DSR:	XX																																																							
REL:	XX																																																							
PROD:	XX	TITLE																																																						
ENGR:	XX	ASSY, XID 46MM 700mA																																																						
CHKD:	XX	DWG SIZE																																																						
	XX	C																																																						
	XX	PART NUMBER																																																						
	XX	SCALE: 3:000																																																						
	XX	REV: 3																																																						
	XX	SHEET 2 OF 2																																																						
<p style="font-size: small;">-CONFIDENTIAL- THIS DOCUMENT IS AND CONTAINS CONFIDENTIAL AND TRADE SECRET INFORMATION. IT IS THE PROPERTY OF XICATO INC. AND IS TO BE RETURNED UPON REQUEST AND IS NOT TO BE REPRODUCED, COPIED, OR DISCLOSED TO ANY OTHER PERSONS WITHOUT THE WRITTEN CONSENT OF XICATO INC.</p>		<p style="font-size: small;">-CONFIDENTIAL- THIS DOCUMENT IS AND CONTAINS CONFIDENTIAL AND TRADE SECRET INFORMATION. IT IS THE PROPERTY OF XICATO INC. AND IS TO BE RETURNED UPON REQUEST AND IS NOT TO BE REPRODUCED, COPIED, OR DISCLOSED TO ANY OTHER PERSONS WITHOUT THE WRITTEN CONSENT OF XICATO INC.</p>																																																						
4	3	2	1																																																					

XID WIRING DIAGRAM

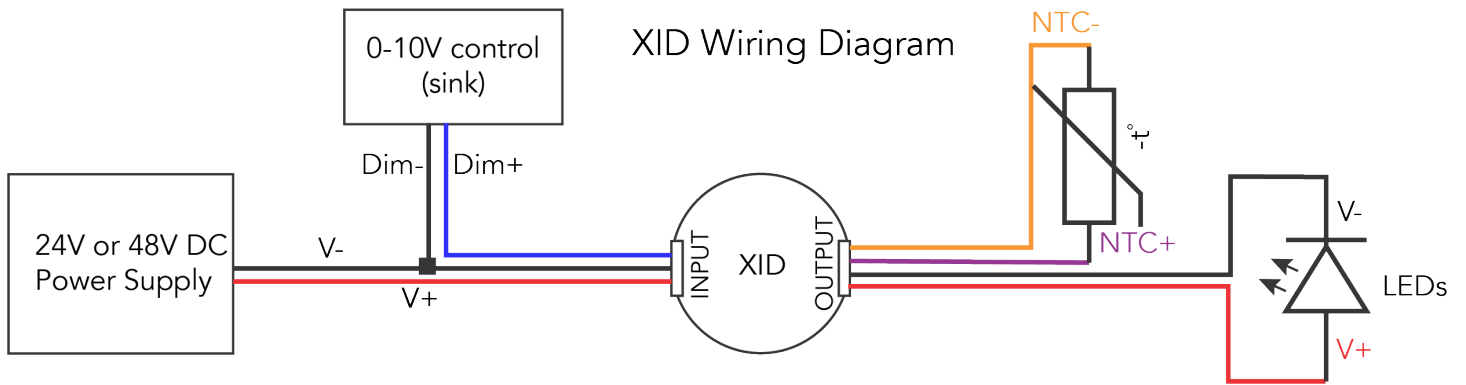

Figure 2: XID wiring diagram

XID PERFORMANCE VS. INTENSITY AND VF

EXAMPLE XID EFFICIENCY BASED ON DIE CONFIGURATION AND INTENSITY

Efficiency is calculated as power delivered to LED light source(s), divided by power into XID. All data is for 48V input to XID01-50C1D6P14-A6. Maximum Vf must remain -3Vdc below input voltage.

Intensity (dim level):	100%				75%				50%			
	Vf	Total	Adder	Efficiency	Vf	Total	Adder	Efficiency	Vf	Total	Adder	Efficiency
1x1	3.05	6.29	2.02	67.9%	2.99	4.64	1.50	67.7%	2.91	3.11	1.07	65.4%
2x1	6.12	10.85	2.28	79.0%	5.98	8.02	1.74	78.3%	5.84	5.37	1.28	76.1%
4x2	12.12	19.50	2.48	87.2%	11.83	14.40	2.00	86.1%	11.50	9.60	1.55	83.8%
5x2	15.08	24.06	2.95	87.7%	14.79	17.76	2.23	87.4%	14.43	11.75	1.65	86.0%
6x2	17.78	27.70	2.81	89.9%	17.42	20.49	2.20	89.3%	17.03	13.59	1.67	87.7%
7x3	20.76	32.10	3.04	90.5%	20.42	23.75	2.31	90.3%	19.99	15.70	1.71	89.1%
8x2	23.80	36.30	2.96	91.9%	23.30	26.70	2.22	91.7%	22.7	17.50	1.65	90.6%
9x3	26.50	39.80	2.72	93.2%	26.00	29.50	2.15	92.7%	25.5	19.40	1.58	91.9%
10x3	30.00	44.80	2.81	93.7%	29.40	33.00	2.11	93.6%	28.7	21.60	1.52	93.0%
11x4	31.01	46.20	2.74	94.1%	30.69	34.20	1.98	94.2%	30.37	22.60	1.33	94.1%
12x4	34.22	50.70	2.82	94.4%	33.86	37.50	1.91	94.9%	33.4	24.60	1.22	95.0%

XID EFFICIENCY VS. INTENSITY AND FORWARD VOLTAGE

y-axis is XID efficiency, x-axis is forward voltage.

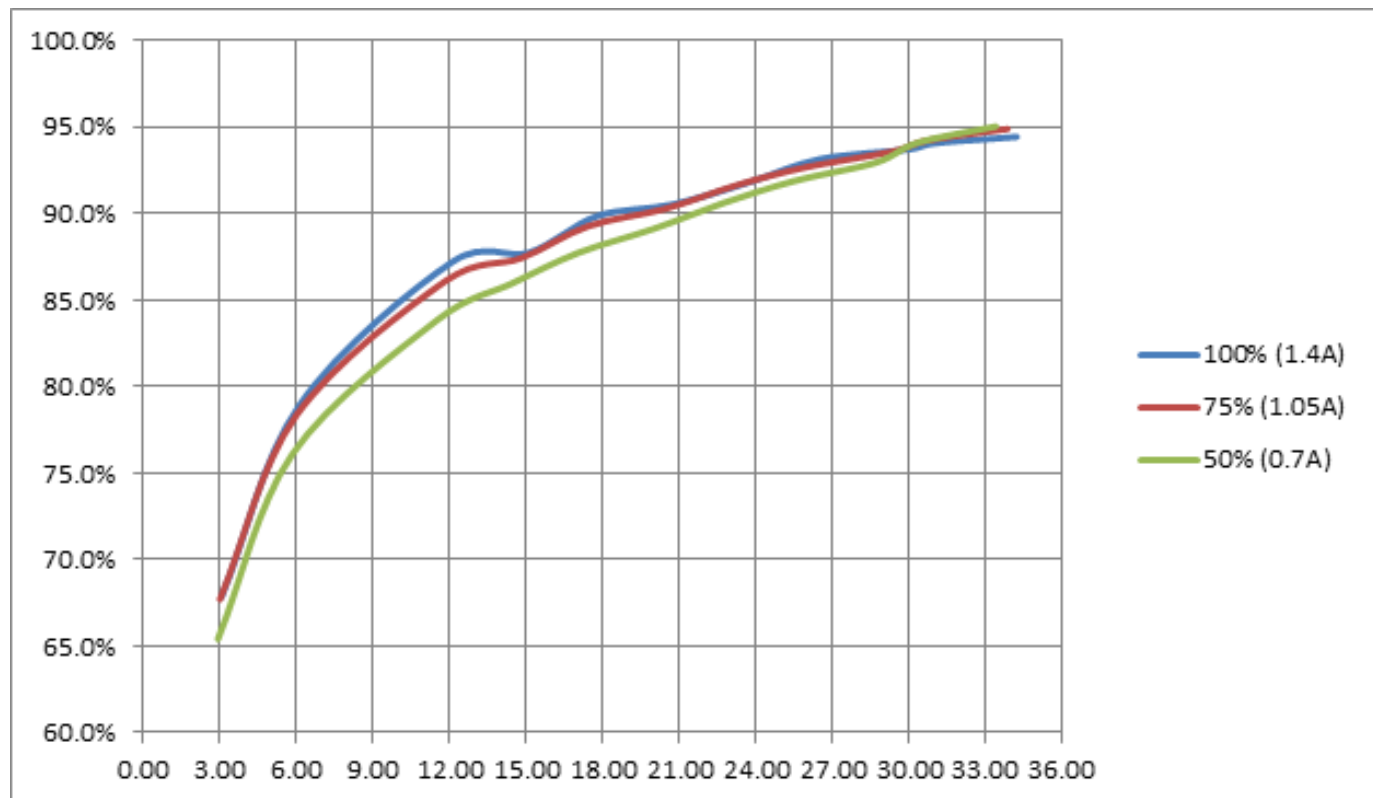

XID EFFICIENCY VS. INTENSITY AT FIXED FORWARD VOLTAGES

y-axis is XID efficiency; x-axis is intensity (% of maximum drive current of 1.4A)

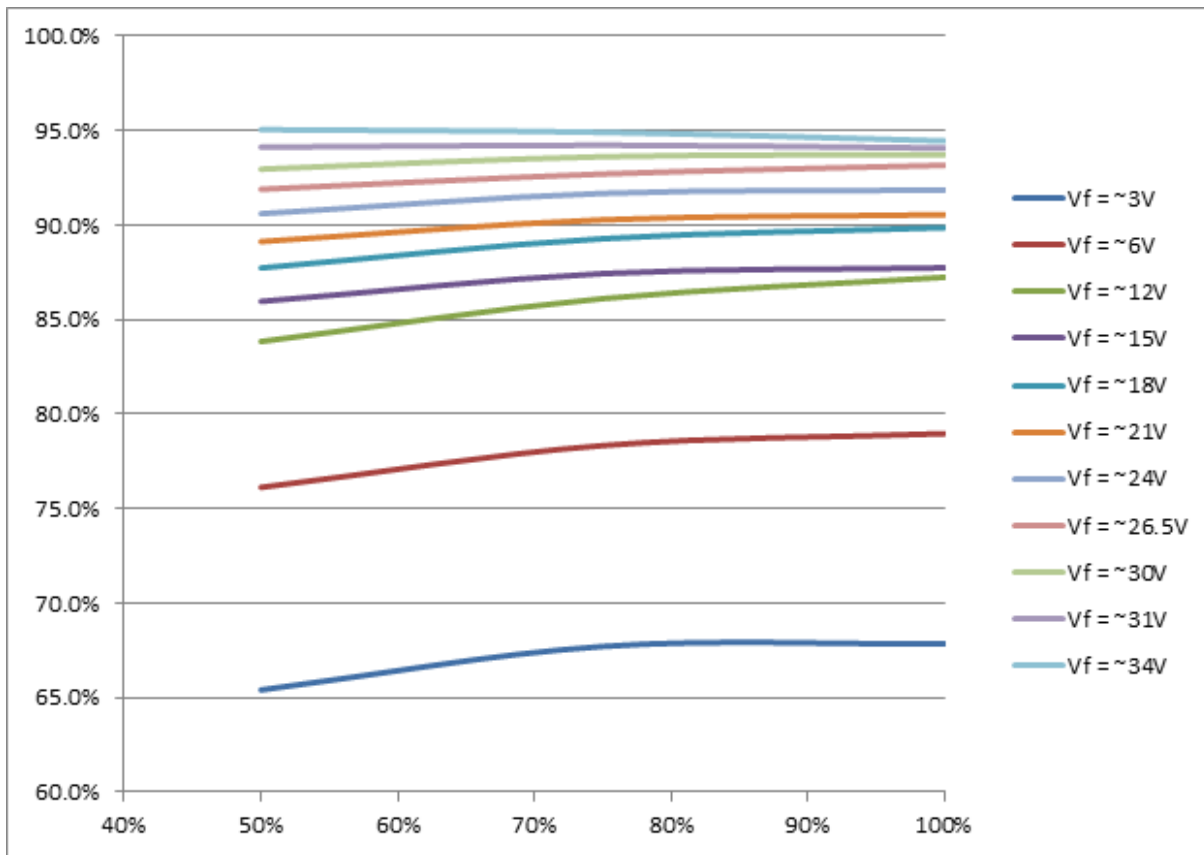

XID POWER CONSUMPTION VS. FORWARD VOLTAGE AND DRIVE CURRENT

y-axis is power consumed by XID (not delivered to LED array); x-axis is forward voltage

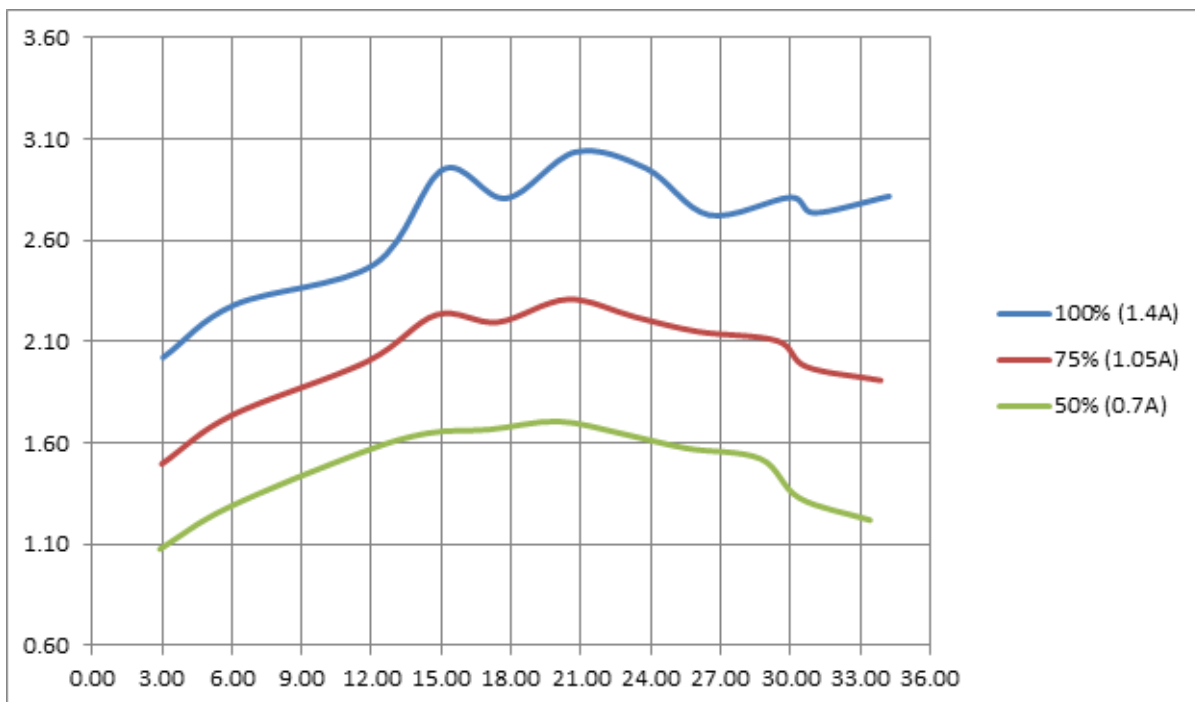

WARRANTY

Warranty duration:	Verifiable 7 years or 50,000 hours of operation at LED intensity > 0%. Temperature and power parameters must be kept within recommended specifications. Verification based on actual operating data stored in each module.
Warranty coverage:	Covers electronics on EVERY module (B0). No failures.
Full warranty text at:	www.xicato.com/support/warranty

REGULATORY & AGENCY APPROVALS

ELECTRICAL SAFETY & HANDLING

CE:	IEC61347-1 (Ed. 3), IEC 61347-2-13 (Ed. 2), IEC 61347-2-13 (Ed. 2);am1
UL:	8750 – Light Emitting Diode (LED) Equipment for Use in Lighting Products 1310 – Standard for Class 2 Power Units. File E494343
Ingress Protection rating:	IP20, Suitable for dry and damp locations
CSA:	C22.2 No. 250.13-14.
ESD Class 3B (HBM). No special ESD handling procedures required.	

CHEMICAL SAFETY

The following chemicals should be avoided, even in small quantities, within the module:

Hydrochloric Acid	MEK (Methyl Ethly Ketone)	Dichloromethane
Sulfuric Acid	MIBK (Methyl Isobutyl Ketone)	Rosin Flux Solder
Nitric Acid	Toluene	Castor Oil
Acetic Acid	Xylene	Lard Oil
Sodium Hydroxide	Benzene	Linseed Oil
Potassium Hydroxide	Gasoline	Petroleum Oil
Ammonia	Mineral Spirits	Silicone Oil
Sulfur (Used in Rubber Processing)	Tetracholoromethane (Carbon tetrachloride – CCl ₄)	Halogenated Hydrocarbons (Containing F, Cl, or Br)

ENVIRONMENTAL SAFETY

RoHS compliant	
Lead content:	None
Mercury content:	None
UV or IRC Emissions:	None

WIRELESS COMPLIANCE

UNITED STATES

FCC NOTICE: This device complies with Part 15 of the FCC Rules. The device meets the requirements for the modular transmitter approval as detailed in FCC public Notice DA00-1407. Transmitter Operation is subject to the following two conditions: (1) This device may not cause harmful interference, and (2) This device must accept any interference received, including interference that may cause undesired operation.

NOTE: This equipment has been tested and found to comply with the limits for a Class B digital device, pursuant to Part 15 of the FCC Rules. These limits are designed to provide reasonable protection against harmful interference in a residential installation. This equipment generates and can radiate radio frequency energy and, if not installed and used in accordance with the instructions, may cause harmful interference to radio communications. However, there is no guarantee that interference will not occur in a particular installation. If this equipment does cause harmful interference to radio or television reception, which can be determined by turning the equipment off and on, the user is encouraged to try to correct the interference by one or more of the following measures:

- Reorient or relocate the receiving antenna.
- Increase the separation between the equipment and receiver.
- Connect the equipment into an outlet on a circuit different from that to which the receiver is connected.
- Consult the dealer or an experienced radio/TV technician for help

LABELING REQUIREMENTS: The Original Equipment Manufacturer (OEM) must ensure that FCC labelling requirements are met. This includes a clearly visible label on the outside of the OEM enclosure specifying the appropriate FCC identifier for this product as well as the FCC Notice above. The FCC identifier is FCC ID: WAP2006. In any case the end product must be labeled on the exterior with "FCC ID: WAP2006"

CANADA

ISED NOTICE: The device complies with Canada RSS-GEN Rules. The device meets the requirements for modular transmitter approval as detailed in RSS-GEN. Operation is subject to the following two conditions: (1) This device may not cause harmful interference, and (2) This device must accept any interference received, including interference that may cause undesired operation.

L'appareil est conforme aux Règles RSS-GEN de Canada. L'appareil répond aux exigences d'approbation de l'émetteur modulaire tel que décrit dans RSS-GEN. L'opération est soumise aux deux conditions suivantes: (1) Cet appareil ne doit pas causer d'interférences nuisibles, et (2) Cet appareil doit accepter toute interférence reçue, y compris les interférences pouvant entraîner un fonctionnement indésirable.

ISED INTERFERENCE STATEMENT FOR CANADA

This device complies with Innovation, Science and Economic Development (ISED) Canada licence-exempt RSS standard(s). Operation is subject to the following two conditions: (1) this device may not cause interference, and (2) this device must accept any interference, including interference that may cause undesired operation of the device.

Cet appareil est conforme à la norme sur l'innovation, la science et le développement économique (ISED) norme RSS exempte de licence. L'exploitation est autorisée aux deux conditions suivantes : (1) l'appareil ne doit pas produire de brouillage, et (2) l'utilisateur de l'appareil doit accepter tout brouillage radioélectrique subi, même si le brouillage est susceptible d'en compromettre le fonctionnement.

ISED RADIATION EXPOSURE STATEMENT FOR CANADA

This equipment complies with ISED radiation exposure limits set forth for an uncontrolled environment.

Cet équipement est conforme aux limites d'exposition aux radiations ISED prévues pour un environnement incontrôlé.

LABELING REQUIREMENTS:

The Original Equipment Manufacturer (OEM) must ensure that ISED labelling requirements are met. This includes a clearly visible label on the outside of the OEM enclosure specifying the appropriate IC identifier for this product as well as the ISED Notice above. The IC identifier is 7922A-2006. In any case, the end product must be labeled in its exterior with "IC: 7922A-2006".

EUROPE

Declaration of Conformity: Hereby, Xicato declares that the XIM series products comply with the essential requirements and other relevant provisions of RED 2014/53/EU.

JAPAN

MIC Japan certificate 203-JN0599

KOREA

KC Korea certificate MSIP-CRM-Cyp-2006