

HOLDERS COMPONENTS CBU-BOX

SIMPLIFY INSTALLATION - MAINTAIN SAFETY

- Compatible with CBU-ASD, CBU-TED and LD220WCM.
- Loop in – loop out push fit connectors 20 to 12 AWG.
- Mounting holes pitch 192mm, Ø5mm. Ø69mm cut-out
- Easy access lid for connecting supply on site.
- ULv0 Construction and 500mm prewired LSZH tails on output.



CASAMBI

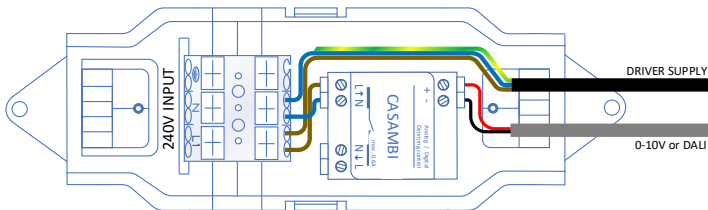

CBU-BOX-ASD

500mm Driver supply tail: Black LSZH 17AWG 3 core flexible
 500mm Dali / 0-10v signal to driver: Grey LSZH 18AWG 2 core screened
 Order Code DALIDIM: 7624-ASD2952
 0-10V: 7624-ASD2662
 (Other fixture profiles available on request)

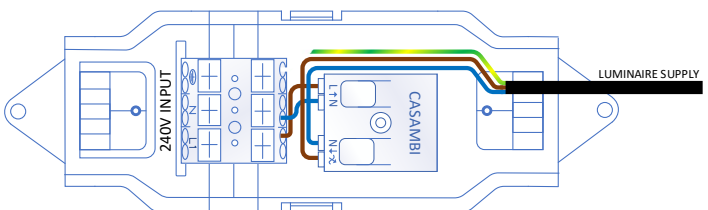

CBU-BOX-TED

500mm Luminaire supply tail: Black LSZH 17AWG 3 core flexible
 Order Code: 7627-TED2694

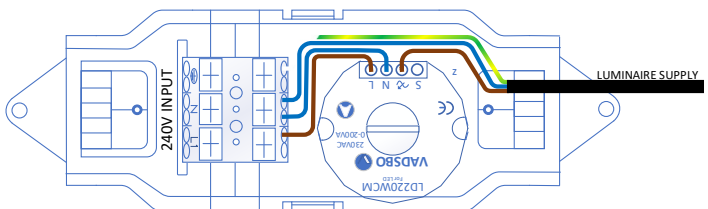

CBU-BOX-LD220

500mm Luminaire supply tail: Black LSZH 17AWG 3 core flexible
 Order Code: 7628-LD220

(Additional cabling is required for pushbutton functionality, this can be easily added by a qualified electrician)

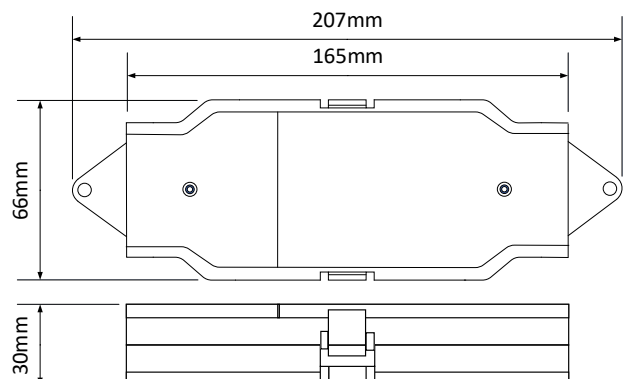
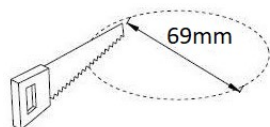

HOLDERS COMPONENTS UK

Block 9, Units 1-4
 Tweedbank Industrial Estate
 Galashiels
 TD1 3RS, United Kingdom
 T: +44 (0)1896 759098
 email: LEDsales@holdersgroup.com

HOLDERS COMPONENTS DE

A division of Holders Technology GmbH
 Woogmorgen 12
 67292 Kirchheimbolanden
 Germany
 T: +49 (0)6352 404220
 email: LEDsalesDE@holdersgroup.com

Holders
Components

Version 1.3 24/10/2018