



PHOS
ENGINEERING LIGHT

EYECONIC SURFACE MOUNT FIXED

STANDARD



4 & 9W

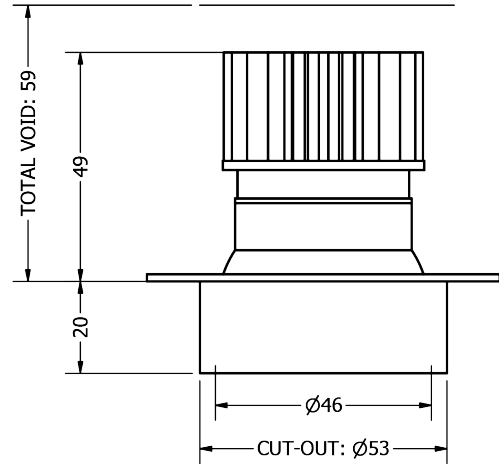
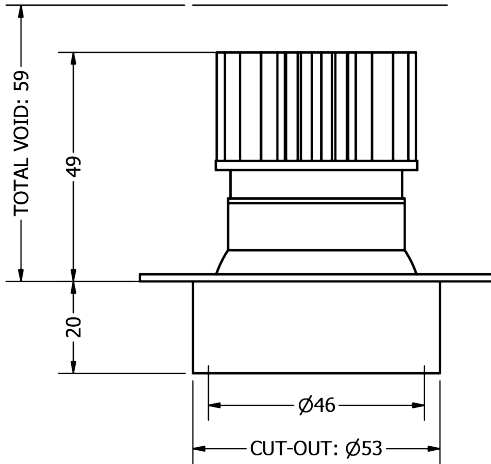

14W

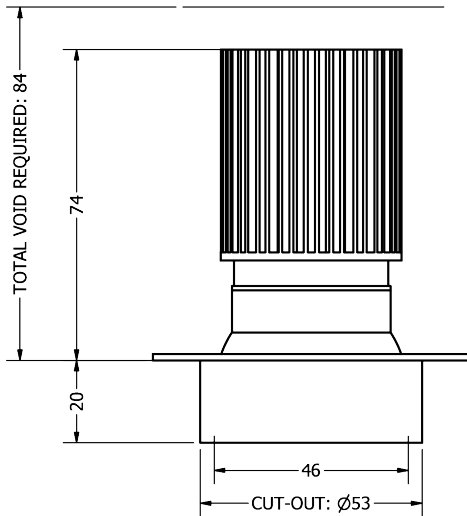

TECHNICAL SPECIFICATIONS

CCT	2700K											
Wattage	4W				9W				14W			
BeamAngle	10°	20°	30°	50°	10°	20°	30°	50°	10°	20°	30°	50°
Luminaire Lumens (lm)	334	303	296	310	481	489	485	504	725	650	630	669
Circuit Watts (c/W)	5.9	6	5.9	5.9	10.5	10.5	10.5	10.5	15.5	15.5	15.5	15.5
LuminaireEfficacy (l/cW)	56	51	50	52	46	47	46	48	47	42	41	43
Luminance (Cd)	6294	1521	888	381	8814	2507	1476	632	14516	3321	1969	832
Light Source (Lm/W)	95	95	95	95	80	80	80	80	69	69	69	69
Engine (Lm/W)	64	64	64	64	59	59	59	59	51	51	51	51
Forward Volatage (Vf)	11.78	11.78	11.78	11.78	12.36	12.36	12.36	12.36	12.65	12.65	12.65	12.65
Current (mA)	350	350	350	350	700	700	700	700	1050	1050	1050	1050

CCT	3000K											
Wattage	4W				9W				14W			
BeamAngle	10°	20°	30°	50°	10°	20°	30°	50°	10°	20°	30°	50°
Luminaire Lumens (lm)	378	342	336	355	635	580	564	597	893	772	772	801
Circuit Watts (c/W)	5.9	5.9	5.9	5.9	10.6	10.5	10.5	10.5	15.8	15.7	15.7	15.6
LuminaireEfficacy (l/cW)	64	58	57	61	60	55	54	57	57	49	49	51
Luminance (Cd)	5827	1674	1018	442	9895	2855	1745	753	14115	4027	2529	1031
Light Source (Lm/W)	95	95	95	95	80	80	80	80	69	69	69	69
Engine (Lm/W)	76	76	76	76	71	71	71	71	62	62	62	62
Forward Volatage (Vf)	11.78	11.78	11.78	11.78	12.36	12.36	12.36	12.36	12.65	12.65	12.65	12.65
Current (mA)	350	350	350	350	700	700	700	700	1050	1050	1050	1050

Binning	2 step MacAdams											
CRI	90+											
TM-30-15	Rf87.43 - Rg99.96											
Lumen Maintenance	LM80											
Lifetime	50,000 hours											
Dimming	Mains Dim, DALI, CASAMBI, 0-10V, Non-dim											

LIGHT CONES

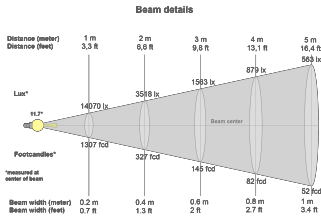

10°

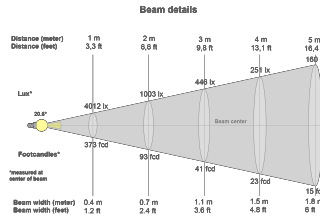

20°

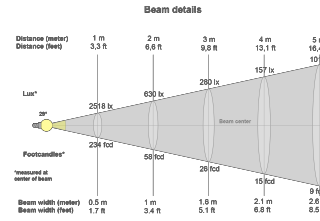

30°

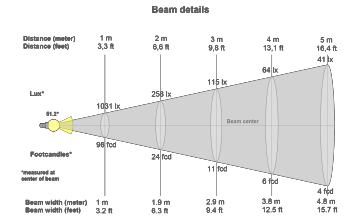

50°

POLAR CURVES

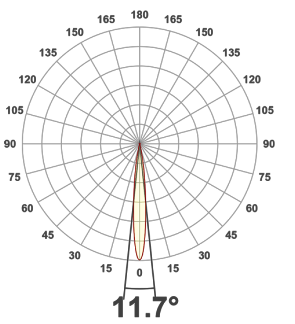

10°

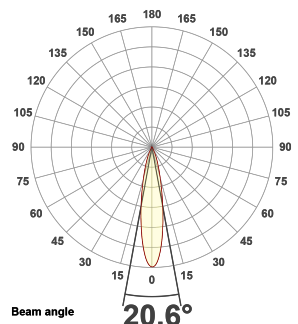

20°

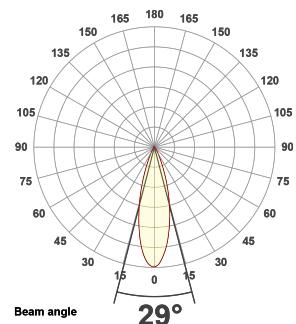

30°

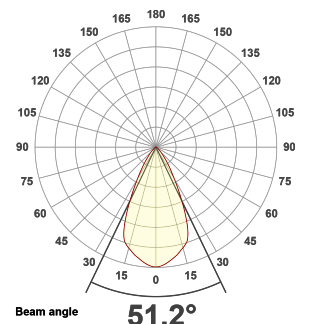

50°

PART CODE BUILDER

Example Code: EY-TF-WT/WT-STD4-27-90-10-350

Family	Variant	Frame Finish	InnerBaffle Finish	Engine	Power	CCT	CRI	Beam Angle	Driver Current
EY	TF	WT	WT	STD	4W	27K	90	10°	350mA
		BT	BT		9W	30K		20°	700mA
		*C	*C		14W			30°	1050mA
								50°	

Frame Example : FR-SM-WT

Variant	Frame Finish
FR-SM	WT
	B2

REGENERATION FOR GENERATIONS



View ReGen Doc



TAKE
Sourcing material locally



MAKE
Responsible manufacture



WASTE
Lifetime duty of care



EYECONIC & ECLIPSE TM66 RESULTS

Category	Points Scored	MAX Possible Points	Assessment
Product Design	111.0	134.0	3.3
Manufacturing	35.0	46.5	3.0
Materials	11.0	24.0	1.8
Ecosystem	36.0	43.0	2.2
Overall Performance	193.0	247.5	2.9
2.5 to 4.0	Excellent circularity		

TM65 Available upon request

Embodied carbon in building services

WE ENCOURAGE ALL FIXTURES TO BE RETURNED TO US SO WE CAN REGEN OR RECYCLE.

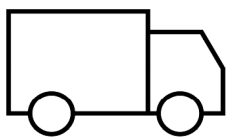

If a product has failed or has become EOL, we can arrange collection of the interchangeable light engines and associated drivers. Once received, we will review the engine to see if it can be **ReGenerated** or **recycled**.



If we can **ReGenerate** the light engine, we will only need to replace the faulty part of the fitting, which can then be restored to life, utilising all of our original optics and bezels.

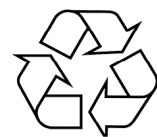

If the unit is beyond the point of repair, we will ensure the raw material is always fully recycled. We encourage all fixtures to be returned to us so we can **ReGen** or **recycle**.

ACCESSORIES



Commissioning Tool

ACCS-TOOL-M-BAFFLE



Wall Wash Removal Tool

Wall Wash ONLY

ACC-WW-TOOL



Snoot

Adjustable ONLY

ACCS-SHOOT



Force Springs

Mini Trim / Round & Square ONLY

CZ7SPRING-CTC



Trimless Bung

Trimless ONLY

ACCS-EY-BUNG

INSERTS



Softening Insert Recessed

ACCS-RECESSED-SOFT



Softening Insert Flush

ACCS-FLUSH-SOFT



Asymmetric Insert Recessed

ACCS-RECESSED-ASYM



Asymmetric Insert Flush

ACCS-FLUSH-ASYM



Elliptical Insert Recessed

ACCS-RECESSED-10X60ELLIPTICAL



Elliptical Insert Flush

ACCS-FLUSH-10X60ELLIPTICAL



Honeycomb Recessed

ACCS-RECESSED-HCOMB



Honeycomb Flush

ACCS-FLUSH-HCOMB



Colour Change Insert Recessed

ACCS-RECESSED-FILTER18K
ACCS-RECESSED-FILTER22K
ACCS-RECESSED-FILTER24K
ACCS-RECESSED-FILTER25K



Colour Change Insert Flush

ACCS-FLUSH-FILTER18K
ACCS-FLUSH-FILTER22K
ACCS-FLUSH-FILTER24K
ACCS-FLUSH-FILTER25K

FINISHES

Every element of your light can be finished in any of the options below, or RAL colour:

PLATED (Interior ONLY)

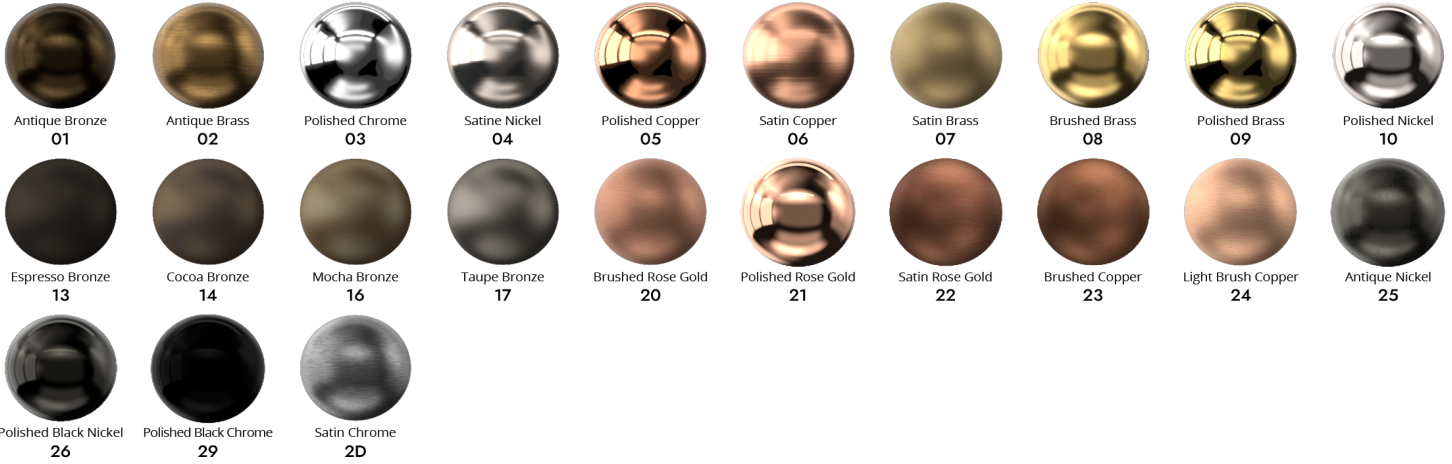

ANODISED (Interior ONLY)

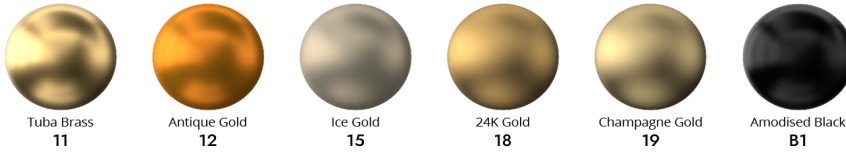

SPECIALITY PLATED (Interior ONLY)

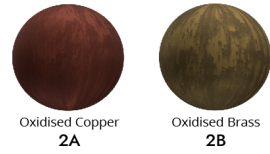

POWDER COAT (Interior & Exterior)



METAL POWDER COAT (Interior & Exterior)

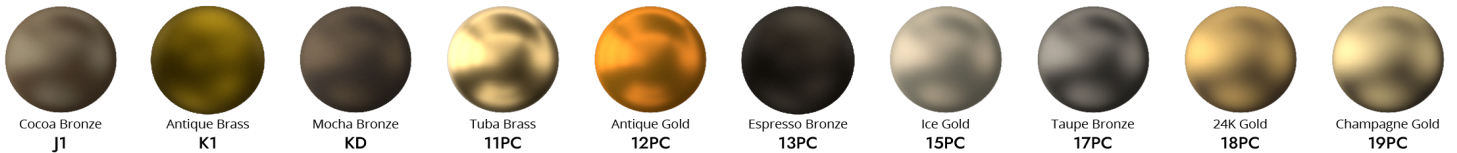

MARINE GRADE (Interior, Exterior & Harsh Environment)

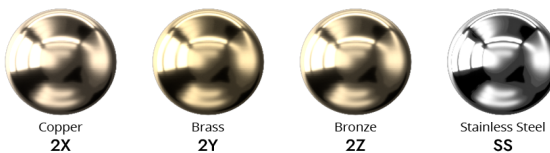

SPECIALITY POWDER COAT (Interior & Exterior)

