



PHOS  
ENGINEERING LIGHT

## PANO MIDI DARKLIGHT SQUARE

GENESIS



13W

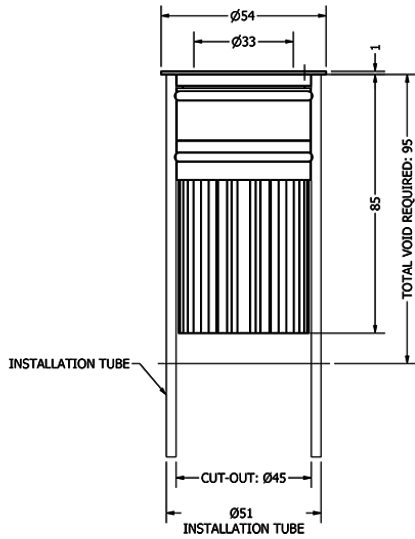

## TECHNICAL SPECIFICATIONS

<b>CCT</b>	<b>2700K</b>			
<b>Wattage</b>	<b>13W</b>			
<b>BeamAngle</b>	20°	25°	30°	45°
<b>Luminaire Lumens (lm)</b>	716	614	664	531
<b>Circuit Watts (c/W)</b>	14.6	14.6	14.6	14.5
<b>LuminaireEfficacy (l/cW)</b>	49	42	46	37
<b>Luminance (Cd)</b>	4678	2652	2273	885
<b>Light Source (Lm/W)</b>	91	91	91	91
<b>Engine (Lm/W)</b>	74	74	74	74
<b>Forward Volatage (Vf)</b>	18.2	18.2	18.2	18.2
<b>Current (mA)</b>	700	700	700	700
<b>CCT</b>	<b>3000K</b>			
<b>Wattage</b>	<b>13W</b>			
<b>BeamAngle</b>	20°	25°	30°	45°
<b>Luminaire Lumens (lm)</b>	764	633	684	555
<b>Circuit Watts (c/W)</b>	14.7	14.6	14.6	14.6
<b>LuminaireEfficacy (l/cW)</b>	52	43	47	38
<b>Luminance (Cd)</b>	4973	2798	2359	907
<b>Light Source (Lm/W)</b>	97	97	97	97
<b>Engine (Lm/W)</b>	78	78	78	78
<b>Forward Volatage (Vf)</b>	18.2	18.2	18.2	18.2
<b>Current (mA)</b>	700	700	700	700
<b>Binning</b>	2 step MacAdams			
<b>CRI</b>	98+			
<b>TM-30-15</b>	Rf97.26 - Rg100.74			
<b>Lumen Maintenance</b>	LM80			
<b>Lifetime</b>	50,000 hours			
<b>Dimming</b>	Mains Dim, DALI, CASAMBI, 0-10V, Non-dim			

## LIGHT CONES

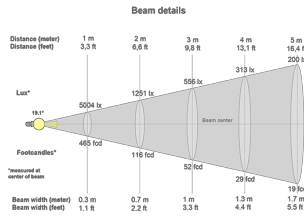

20°

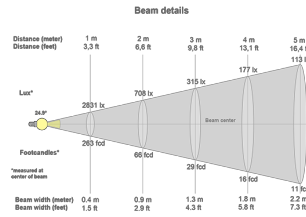

25°

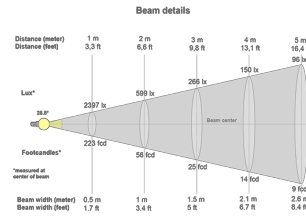

30°

## POLAR CURVES

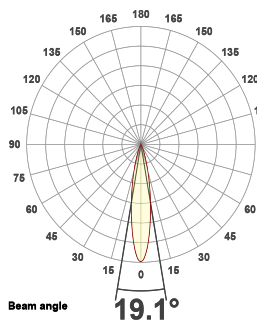

20°

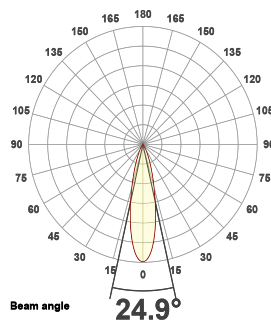

25°

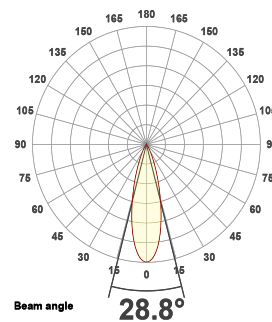

30°

## PART CODE BUILDER

Example Code: MD-PD-SQ-WT-GEN13-27-98-20-700

Family	Variant	Bezel Finish	Engine	Power	CCT	CRI	Beam Angle	Driver Current
MD	PD-SQ	WT	GEN	13W	27K	98	20°	700mA
		BT			30K		25°	
		*C					30°	
							45°	

# REGENERATION FOR GENERATIONS



View ReGen Doc



**TAKE**  
Sourcing material locally



**MAKE**  
Responsible manufacture



**WASTE**  
Lifetime duty of care



## SOFT TM66 RESULTS

Category	Points Scored	MAX Possible Points	Assessment
Product Design	111.0	134.0	3.3
Manufacturing	35.0	46.5	3.0
Materials	11.0	24.0	1.8
Ecosystem	36.0	43.0	3.3
Overall Performance	193.0	247.5	2.9
2.5 to 4.0	Excellent circularity		

TM65 Available upon request

*Embodied carbon in building services*

WE ENCOURAGE ALL FIXTURES TO BE RETURNED TO US SO WE CAN REGEN OR RECYCLE.

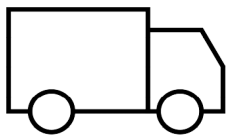

If a product has failed or has become EOL, we can arrange collection of the interchangeable light engines and associated drivers. Once received, we will review the engine to see if it can be **ReGenerated** or **recycled**.



If we can **ReGenerate** the light engine, we will only need to replace the faulty part of the fitting, which can then be restored to life, utilising all of our original optics and bezels.

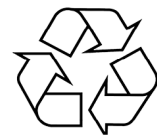

If the unit is beyond the point of repair, we will ensure the raw material is always fully recycled. We encourage all fixtures to be returned to us so we can **ReGen** or **recycle**.

**ACCESSORIES**



Midi Installation Tube

ACC-MD-TUBE

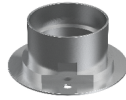

Midi Collar Tube

ACCS-MD-COLLARTUBE

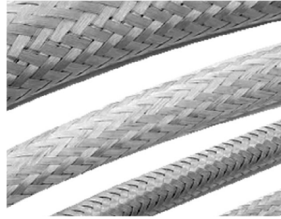

Exterior Cable Sleeve

ACCS-E-CABLESLEEVE-5MM

**INSERTS**



Elliptical Insert

*NOT available for square versions*

EL



Asymmetric Insert

*NOT available for square versions*

AS



Softening Insert

SL

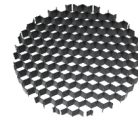

Honeycomb Insert

HC



Halfmoon Insert

*NOT available for square versions*

HM



Colour Change Insert

CCT: 18K

CCT: 22K

CCT: 24K

CCT: 25K



## FINISHES

Every element of your light can be finished in any of the options below, or RAL colour:

### PLATED (Interior ONLY)

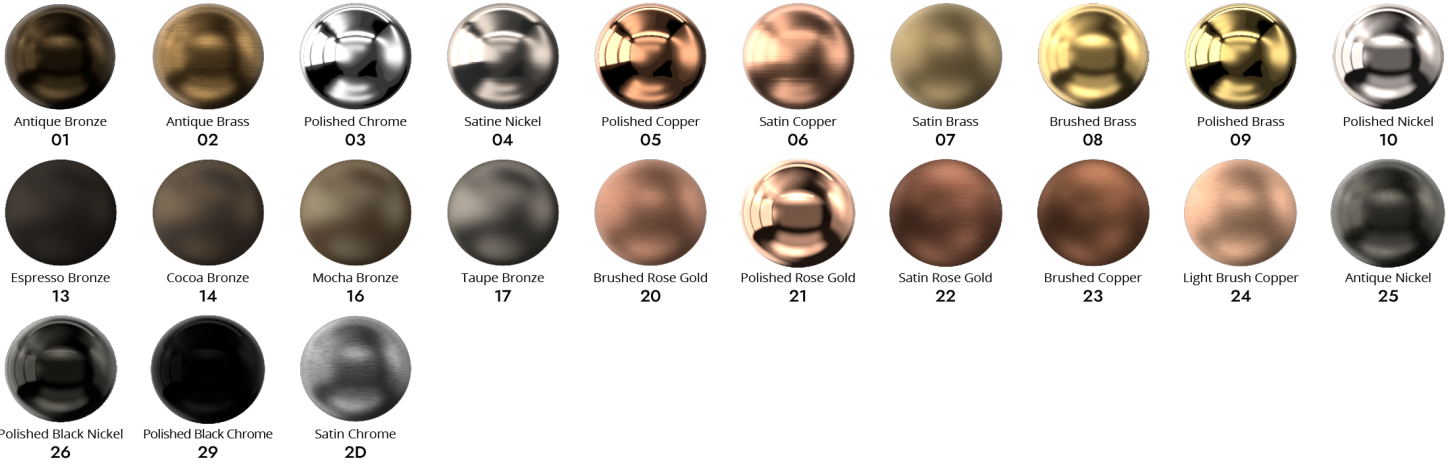

### ANODISED (Interior ONLY)

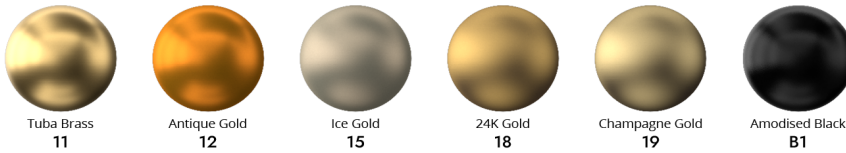

### SPECIALITY PLATED (Interior ONLY)

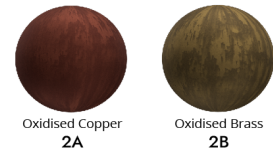

### POWDER COAT (Interior & Exterior)



### METAL POWDER COAT (Interior & Exterior)

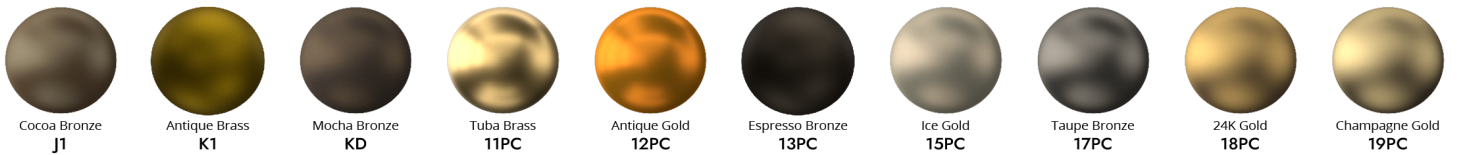

### MARINE GRADE (Interior, Exterior & Harsh Environment)

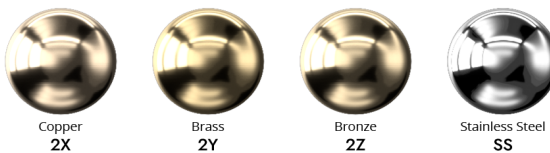

### SPECIALITY POWDER COAT (Interior & Exterior)

