

MOTO-ZERO COMPASSO 68

ORDERING CODE: M665BC22-903016DC10

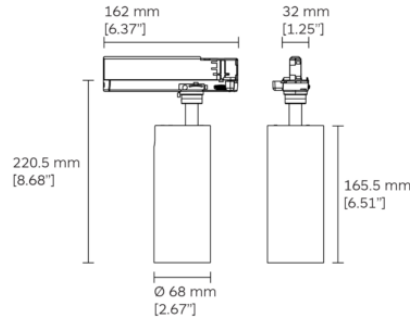

DESCRIPTION

Motorized track mounted spotlight with light head and mounting arm in cast aluminium.

Moto-Zero Compasso is available in 3 different light head diameters: 40mm, 68mm and 100mm.

Moto-Zero Compasso Zoom is available in 4 diameters: 40mm, 68mm, 80mm and 130 mm.

The integrated track adapter with built-in driver is compatible with 3 phase eurotype track.

Two DC motors drive the movements of the fixtures, tilting them vertically up to 90° and rotating horizontally 350°.

For the Moto-Zero Zoom series, a third motor controls a special lens, which allows the user to shape the light beam from narrow to wide diffuse.

The movements and the beam shaping of the fixture, as well as the intensity and the colour tuning of the light, are controlled via CASAMBI™ application.

LIGHT SOURCE AND PERFORMANCE

LIGHT SOURCE: LED Built-in with body - High Efficacy BC22 - LED

SDCM: 3-step MacAdam

COLOR TEMPERATURE: 30 - 3000K

CRI: 90

IP: 20

LED POWER: 12

NOMINAL LUMEN: 1550

SYSTEM POWER: 14

DELIVERED LUMEN: 1220

BEAM ANGLE (BA°): 16

MOUNTING

Track

OPTIC

Lens or Reflector (only for Moto-Zero Compasso 68 TW).
Beam Angle: Super Narrow (7°) / Narrow / Medium / Wide.
Moto-Zero Zoom series: special lenses with beam shaping technology.

DIMMING OPTIONS

DC - CASAMBI



PRODUCT CODE	LIGHT SOURCE CODE	-	CRI	CCT	BEAM ANGLE (BA°)	DIMMING OPTIONS	FINISH
M665	BC22	-	90	30	16	DC	10 - Black

ACCESSORIES



Linear Spread

2A51

We reserve the right to change specifications without prior notification.

MOTO-ZERO COMPASSO 68

ORDERING CODE: M665BC22-903016DC10



Visor

2A60



Snoot

2A65



Honeycomb Louvre

2B95

NOTES:

Lumenetix:

Tuning range: 1650-8000K. Gradients of saturated colours from 1-100% can be added to colour points within the tuning range.

The values in the nominal lumen are referring to the peak lumen.

We reserve the right to change specifications without prior notification.